



PMG1005-T20B

GPON SFU with 1-port GbE LAN

The Zyxel PMG1005-T20B GPON SFU with 1-port GbE LAN comes with one GPON uplink and one GbE LAN downlink to serve as a simple bridge to offer Gigabit data access to subscribers. Comparing with other FTTH solutions, the Gigabit Passive Optical Networking (GPON) features Point-to-Multi-Point (P2MP) architecture that enables service providers or system integrators to provide Gigabit broadband access with the least CAPEX investment to make it very competitive and popular among operators.

Product roadmaps incorporating the Zyxel PMG1005-T20B bring more flexibility for system integrators to deploy their service networks as GPON networks allow containing various deployment scenarios within one single service site. Instead of deploying a specific type of home gateway, the two-box solution allows system integrators to provide multiple product combinations to fulfill different scenario requirements through the same user interface.

The Zyxel PMG1005-T20B is fully compliant with the ITU-T G.984 GPON standard and has been field-proven on E2E Interoperability with Zyxel GPON OLT product series, making it a brilliant choice as an entry-level GPON Single Family Unit (SFU).



Gigabit data access via fiber



Simple bridge design for flexible deployment



Field-proven interoperability with Zyxel OLT

Benefits

High-speed Gigabit offers seamless triple-play services

As broadband wireline access technology evolves, it increases not only the number of subscriptions, but also the need for bandwidth capacity by each individual home or enterprise unit. The high-bandwidth services, such as 4K/8K HD video streaming, cloud-based data storage and more, have become a trend and significantly changed users' behavior. In the mean time, they also triggered the

strong demand for higher access speed to migrate to the Gigabit era. The Zyxel PMG1005-T20B GPON SFU with 1-port GbE LAN is a simple bridge that enables service providers to address Gigabit data access for subscribers under the P2MP structure and to realize high-quality triple-play services such as voice, data and video over fiber optics.



Fiber with typical speed of over 1 Gbps within 20 km*

G.fast



G.fast with typical speed of up to 1 Gbps within 300 - 400m**

VDSL
ADSL



DSL with typical speed of up to 2 - 100 Mbps within 800 - 1.5 km

* Download speed: 2.5 Gbps/Upload speed: 1 Gbps
** Download speed: 800 Mbps/Upload speed: 200 Mbps

Same user experience with advanced product combinations

With the P2MP structure, service providers are able to provide various service packages to fulfill different user requirements into single deployment sites with the most cost-effective product combinations. The Zyxel PMG1005-T20B can perform as a Layer-2 Optical Network Terminal (ONT) followed by any Layer-3 devices such as routers, WiFi APs, and home gateways, and more depending on

individual subscriber's preference. Since the WLAN technology and other gateway interface requirements evolves rapidly, using a two-box solution reserves space for service providers to substitute the second box with the same user interface if the users keep using the PMG1005-T20B as their GPON access terminal.

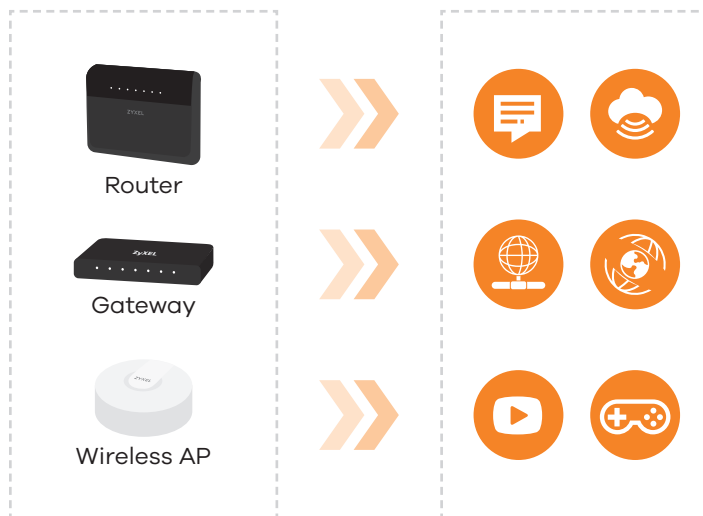
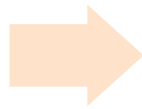

Zyxel E2E readiness improves product time-to-market

The Zyxel PMG1005-T20B is one of Zyxel's GPON ONT product series that guarantees E2E interoperability (IOP) with Zyxel's OLT PON line cards. The Zyxel PMG1005-T20B is equipped with the Zyxel-specific OMCI parameter that works perfectly with Zyxel's EMS and OLT systems. With the E2E-capable parameters, Zyxel provides not only the

standard parameters defined by OMCI but also some specific parameters that help service providers to diagnose, operate and manage their fiber networks. Leveraging this E2E-ready solution helps service providers to shorten the product time-to-market as well as to avoid the huge IOP investments.

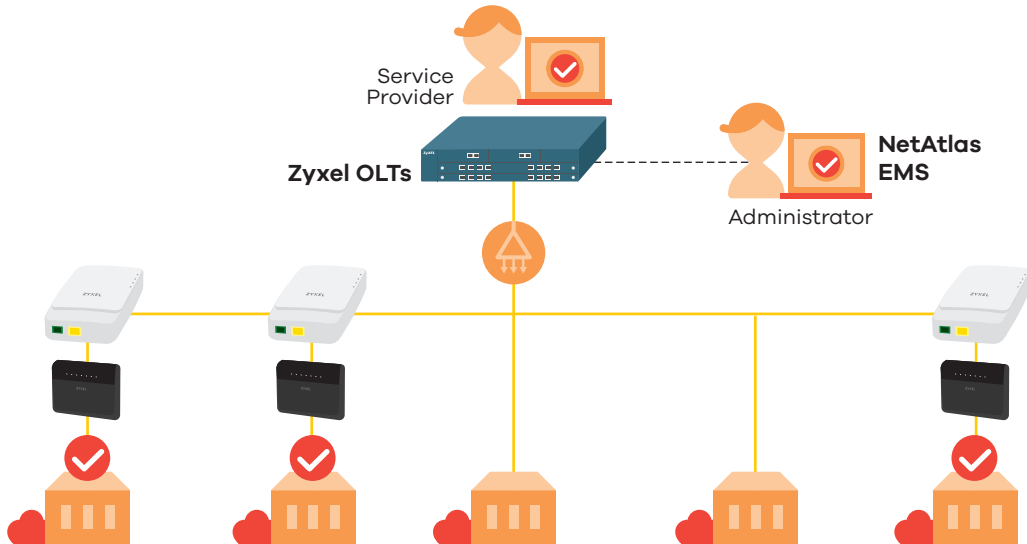

Application Diagram

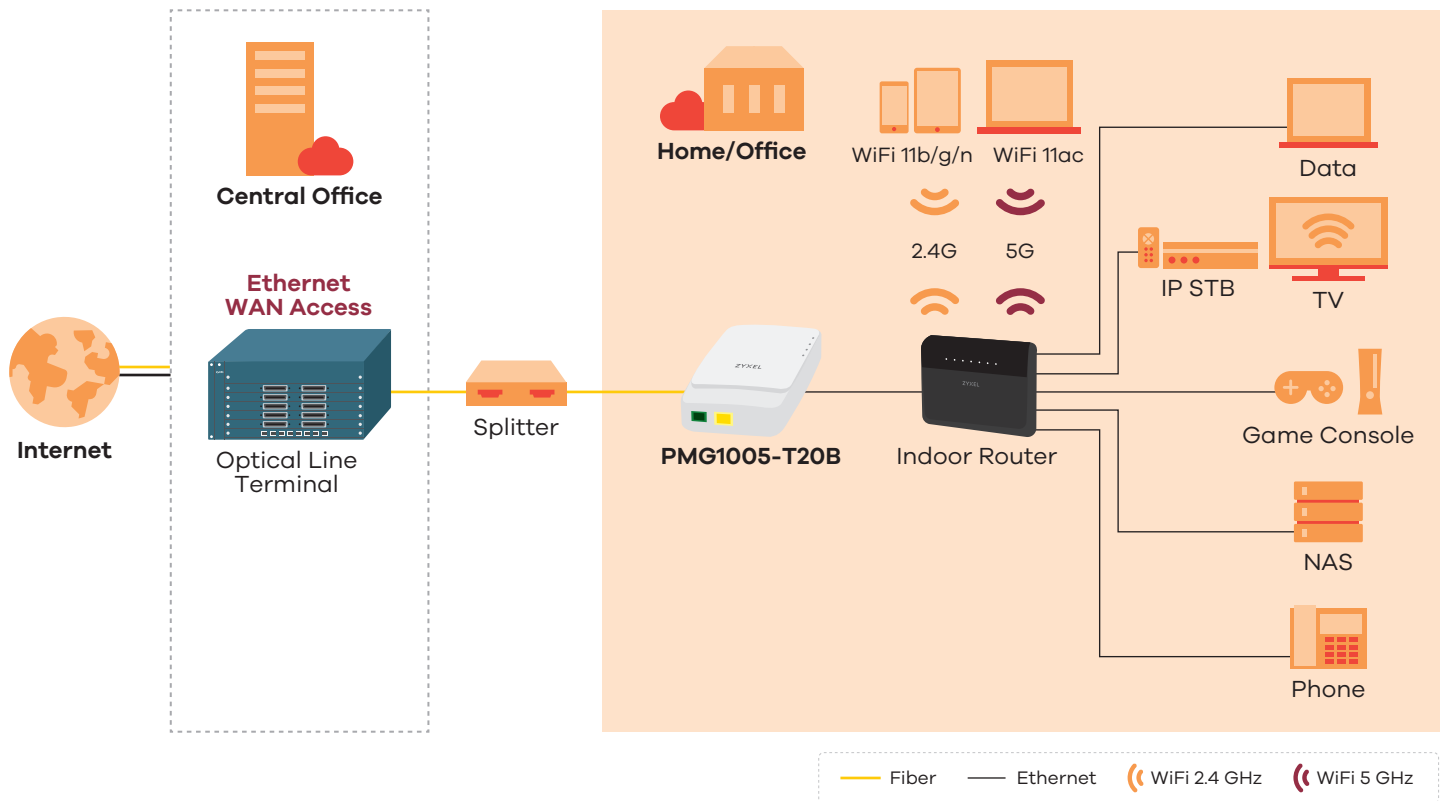

Specifications

System Specifications

GPON Features

- Comply ITU-T G.984/G.988 GPON standard:
 - G.984.1 general characteristics
 - G.984.2 Physical Media Dependent (PMD) layer specifications
 - G.984.3 transmission convergence layer specifications
 - G.984.4 ONT management and control interface specification
 - G.988 ONU Management and Control Interface (OMCI) specification
- Comply with class B+ type PMD
- Transmission rate: 2.488 Gbps (DS)/1.244 Gbps (US)
- Wavelength: 1490 nm (DS) & 1310 nm (US)
- Physical distance reach to 20 km
- Dynamic Bandwidth Allocation (DBA)
- Configurable AES DS and FEC DS/US
- GPON Encapsulation Method (GEM) supports Ethernet packet
- Supports GEM header removal/insertion and data extraction/segmentation (GEM SAR)
- Flexible Mapping between TCON and GEM port
- Support up to 8 T-CONTs with 32 GEM ports.
- Support 8 priority queues (US) on each GPON T-CONT.

Layer 2 Networking Features

- MAC address learning
- MAC filtering
- Multicast transparent
- IPv6 address transparent

Multicast

- IGMP v1/v2/v3 snooping
- IGMP immediate leave
- IPv6 MLD v1/v2 snooping

VLAN Functional Specifications

- VLAN IEEE 802.1Q
- Ethernet port based VLAN tag and un-tag
- Protocol based VLAN support
- 1:1 VLAN, N:1 VLAN, VLAN transparent bridge
- LAN port-based VLAN tag add and tag removal
- Q in Q VLAN

QoS

- 802.1p priority with 4 queues
- Flow mapping base on 802.1p/VLAN ID

Management

- Standard OMCI (ITU-T G.984.4)
- Telnet (CLI)
- Web GUI (HTTP)
- Firmware upgrade via FTP/TFTP/HTTP

Hardware Specifications

- WAN: One Giga optical interface (SC/APC)
- LAN: One 10/100/1000 auto MDI/MDI-X RJ-45
- Reset button: One reset/restore factory default button
- Power switch: Push-push type button
- LED indicators:
 - Power
 - Passive Optical Network (PON)
 - LOS
 - LAN

- Power supply: 12 V/DC 0.5 A
- Power consumption: 2.638 Watt max.

Physical Specifications

- Item dimensions (WxDxH): 109.4 x 83.6 x 36.5 mm (4.3" x 3.29" x 1.44")
- Item weight: 113g (0.25 lb.)
- Packing dimensions (WxDxH): 131 x 130 x 95 mm (5.16" x 5.12" x 3.74")
- Packing weight: 342g (0.75 lb.)

Environmental Specifications

Operating Environment

- Temperature: 0°C to 45°C (32°F to 113°F)
- Humidity: 10% to 90% RH (Non-condensing)

Storage Environment

- Temperature: -30°C to 70°C (-22°F to 158°F)
- Humidity: 10% to 95% RH (Non-condensing)

Certification

- CE
- Safety: CE LVD
- Energy Saving: ErP

Package Contents

- GPON SFU
- Power adapter
- Ethernet cable
- Safety warning & DoC letter
- Quick start guide

Front Panel

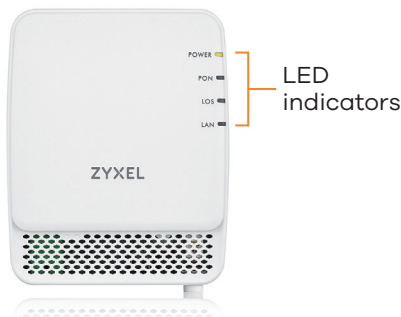

Rear Panel

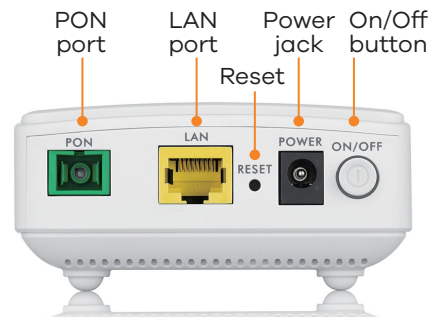

For more product information, visit us on the web at www.zyxel.com

Copyright © 2018 Zyxel Communications Corp. All rights reserved. Zyxel, Zyxel logo are registered trademarks of Zyxel Communications Corp. All other brands, product names, or trademarks mentioned are the property of their respective owners. All specifications are subject to change without notice.

Datasheet [PMG1005-T20B](#)



5-100-01918001 04/18